



MINI SCAN HPE



PROFESSIONAL SHOW LIGHTING



The excellent luminous efficiency and outstanding versatility of MINI SCAN HPE make it ideal, not just for discotheques, but also for theatres, television studios and service lighting installations.

MINI SCAN HPE is an intelligent moving mirror luminaire which combines quality, advanced technology, reliability and a host of special effects in an extremely compact unit. It is the perfect synthesis of all the features which have made Clay Paky's large professional scanners a world-wide success.

If you are looking for a compact, powerful projector, which is innovative, elegant, packed with graphic features, capable of meeting any requirements from the most simple to the most complex, yet still within the scope of any budget, then MINI SCAN HPE is the answer to your dreams.

EXCEPTIONAL LUMINOUS EFFICIENCY

MINI SCAN HPE is so packed with power that it could only have been produced with the design flair and technical know-how of Clay Paky. The lamp-optical system combination provides almost double the luminous efficiency (+95%) of standard units; a result which is absolutely unique among moving mirror spotlights of this size, which means that the MINI SCAN HPE has all the power necessary for longer range applications while still offering a low power consumption.

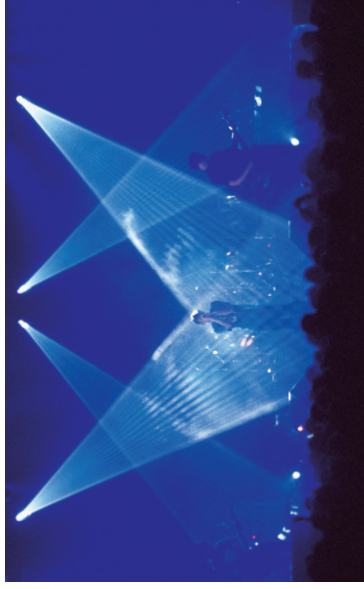
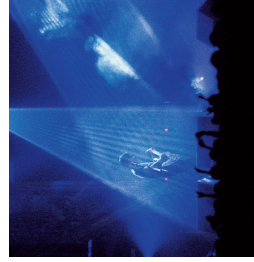
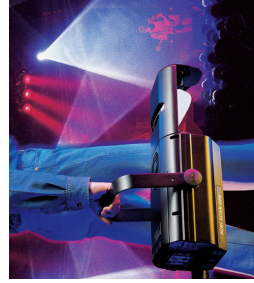
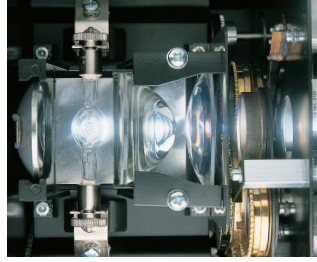

LAMP EFFICIENCY

MINI SCAN HPE uses a 300 watt Osram HTI 300/DX lamp, with a luminous flux of 22,000 lumen, an average life of 750 hours and a colour temperature of 6,500K. This extremely efficient and reliable lamp

PERFECT PROJECTION

The special design of the optical system with twin lens condenser and high luminous efficiency mirror ball, combined with the use of high quality components, means that, even at maximum aperture settings, the beam from the MINI SCAN HPE appears sharp and uniform over the

entire illuminated surface. Image focusing is ensured by a standard lens with an aperture of 16,6", which, if required, can be substituted with an optional 12,6" lens, or with an optional trioptic 13,6" lens.

THE COLOUR SYSTEM

The colour system comprises a colour disc and a second effects disc which can be combined to obtain 36 different colour combinations.

All the colours are obtained through perfectly pure dichroic filters, which are freely interchangeable so that users can devise their own personalised "palette". The effects disc contains a special blue colour filter and a filter to simulate Wood light.

The two colour temperature correction filters of 3,200 and 6,000K on the effects disc underline the suitability of MINI SCAN HPE for professional lighting applications.

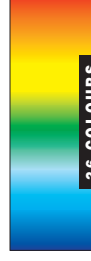

36 COLOURS

The rotation speed of the colour wheel can be varied to obtain effects such as bicolor beams and a rainbow effect.



DIFUSION EFFECT

The light beam from the MINI SCAN HPE can be diffused to create colour backgrounds for a highly suggestive theatrical effect. Two different diffusion levels may be obtained using the two Frost filters fitted as standard on the effects disc.

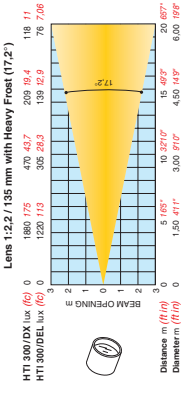
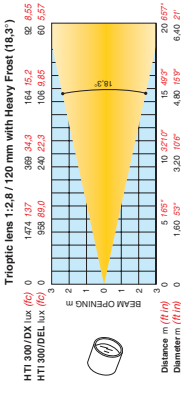
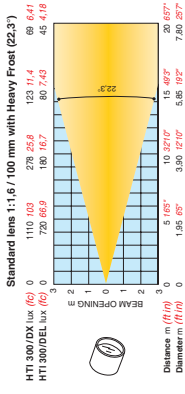
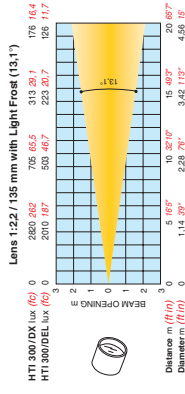
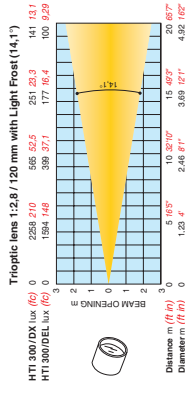
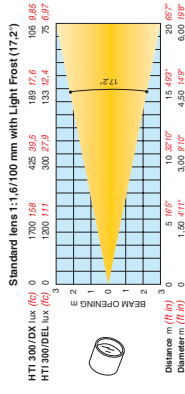

PRISM EFFECT

All the effects obtained with the gobos can be further enhanced by interposing the 3-way multiplier prism to create suggestive multiple images.

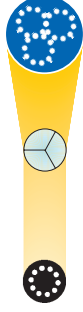

MIRROR

Mirror movement is smooth and gradual thanks to the high-resolution microstepping motors, and extends to 150° in pan and 110° in tilt, thereby providing ample coverage.

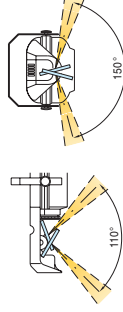

DYNAMIC GRAPHIC EFFECTS

The MINI SCAN HPE's graphic equipment is based on a group of six rotating gobos which can spin in either direction at variable speed, generating an enormous number of different effects. Gobo rotation is indexed at 540° thereby allowing effects to be precisely recreated on any number of different



projectors. The standard gobo system, which also comprises two dichroic gobos, can be modified to suit the specific needs of the user as all the gobos are fully interchangeable. The Clay Paky catalogue offers a wide choice of gobos and custom gobos are available on request.



METAL GOBOS Ø 25.5 mm



DICHROIC GOBOS Ø 25.5 mm



DIMMER, STOPPER, STROBE

The movement of the mechanical dimmer is smooth, gradual and precise, with linear adjustable movement from 0 to 100% and instantaneous beam blocking.

The strobe effect is highly spectacular, and can be adjusted from 1 to 11 flashes per second, with a blackout time of only 40 milliseconds.

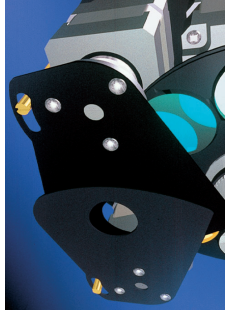

UNIQUELY COMPACT

When designing the MINI SCAN HPE, Clay Paky engineers excelled themselves; not only did they succeed in concentrating an enormous range of features and high-level performance in an extremely compact unit - they did so without

compromising in any way the renowned reliability of all Clay Paky projectors. The compact design means easy handling and easy installation and makes a significant contribution to the overall aesthetics of the lighting installation.



ACCURATE, RELIABLE ELECTRONICS

MINI SCAN HPE's electronic system is totally reliable, thanks to the experience of the electronics engineers at Pulsar; all projector functions are fully controlled from the lighting desk on seven channels using standard DMX and RS 232 (PMX) digital signals.



| 1 | 2 | 3 | 4 | 5 | 6 | 7 |
|---------------------------------|-----------------------------------|-----------------------------------|-----------------------------------|-----------------------------------|-----------------------------------|-----------------------------------|
| Color disc | Gobo Rotation | Gobo Select | Dimmer Strobe | PAN | TILT | Effects disc |
| 100% 75% 50% 25% 0% | STOP 90° 180° 360° 0° | STOP 90° 180° 360° 0° | STOP 90° 180° 360° 0° | STOP 90° 180° 360° 0° | STOP 90° 180° 360° 0° | STOP 90° 180° 360° 0° |

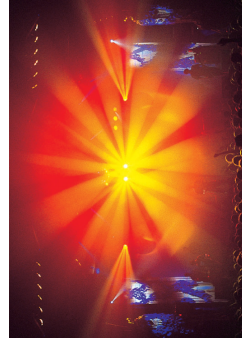
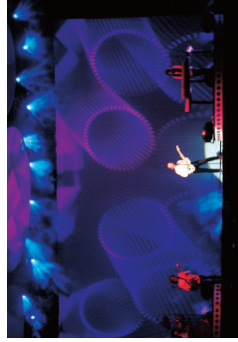
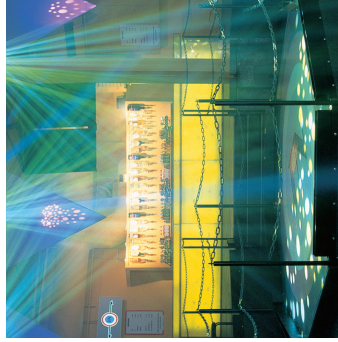

TECHNICAL CHARACTERISTICS

ELECTRO - MECHANICAL SPECIFICATIONS

POWER SUPPLY

- 220 - 240 V 50/60 Hz
- 100 - 120 V 50/60 Hz.

LAMP

- Metal iodide type, fed by built-in power supply unit;
- Type HTI 300/DX: colour temperature 6,500 K, luminous flux 22,000 lumen, cap SFc 10-4, average life 750 h.
- Type HTI 300/DEL: colour temperature 5,700 K, luminous flux 20,000 lumen, cap SFc 10-4, average life 3,000 h, working position P 45.

POWER CONSUMPTION

- 900 VA at 230V 50Hz;

MOTORS

- No. 8 microstepping motors with full microprocessor control.

OPTICAL SYSTEM

OPTICAL UNIT

- Base in die-cast aluminium;
- Twin lens condenser;
- High luminous efficiency mirror.

LENSES

- Standard: 1:1,6 / 100 mm (16,6°).
- Optional: 1:2,2 / 135 mm (12,6°).
- Optional trioptic: 1:2,8 / 120 mm (13,6°).

MIRROR HEAD

MIRROR

- Very high luminous efficiency.

MOVEMENT

- By means of two microstepping motors with microprocessor control.
- Continuously variable speed; maximum values:
 - PAN = 0,4 s (150°)
 - TILT = 0,3 s (110°).
- Continuous, uniform movement; resolution:
 - PAN $\pm 0,3^\circ$ (150°)
 - TILT $\pm 0,2^\circ$ (110°).

CONTROL SYSTEMS

CHANNELS

- No. 7 control channels.

INPUTS

- MINISCAN HPE is designed to accept digital control signals from controllers or computers.
- Digital serial inputs: RS 232/423 (PMX) or DMX 512.

CONSTRUCTION

SAFETY DEVICES

- Automatic power-down in the case of overheating or cooling system failure.
- Automatic power-down when cover is opened.
- Two safety rope fixing points

COOLING

- Forced ventilation supplied by axial fans.

HOUSING

- In die-cast aluminium with epoxy powder coating.

MOUNTING BRACKET

- Steel with epoxy powder coating.
- Two installation positions spaced at 50 mm (1,97").
- Adjustable through 110°.
- Fastening point for safety rope.

OPERATING POSITION

- Operation in any position, limited to the specifications of the lamp used.

WEIGHTS AND DIMENSIONS

- 582 x 238 x 300 mm.
- Version 200 - 240 V: 13 kg (28 lbs 10 ozs).
- Version 100 - 120 V: 16 kg (35 lbs 3 ozs).

ORDER CODES

C11085 Mini Scan HPE 200-240 V

C11086 Mini Scan HPE 100-120 V

C31107 Optional trioptic lens 1:2,8 / 120 mm

C31147 Optional lens 1:2,2 / 135 mm

L10043 Osram HTI 300/DX lamp

L10051 Osram HTI 300/DEL lamp

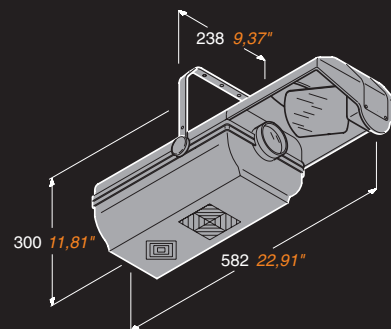

CLAY PAKY S.p.A

Via Pastrengo, 3/b - 24068 Seriate (BG) - Italy - Tel. + 39 - 035 - 654311
Fax + 39 - 035 - 301876 - www.claypaky.it - e-mail: cp.sales@claypaky.it



PROFESSIONAL SHOW LIGHTING